

(No Model.)

5 Sheets—Sheet 1.

A. T. TREGURTHA.

MACHINE FOR APPLYING METAL COVERINGS TO SPOOL HEADS.

No. 557,729.

Patented Apr. 7, 1896.

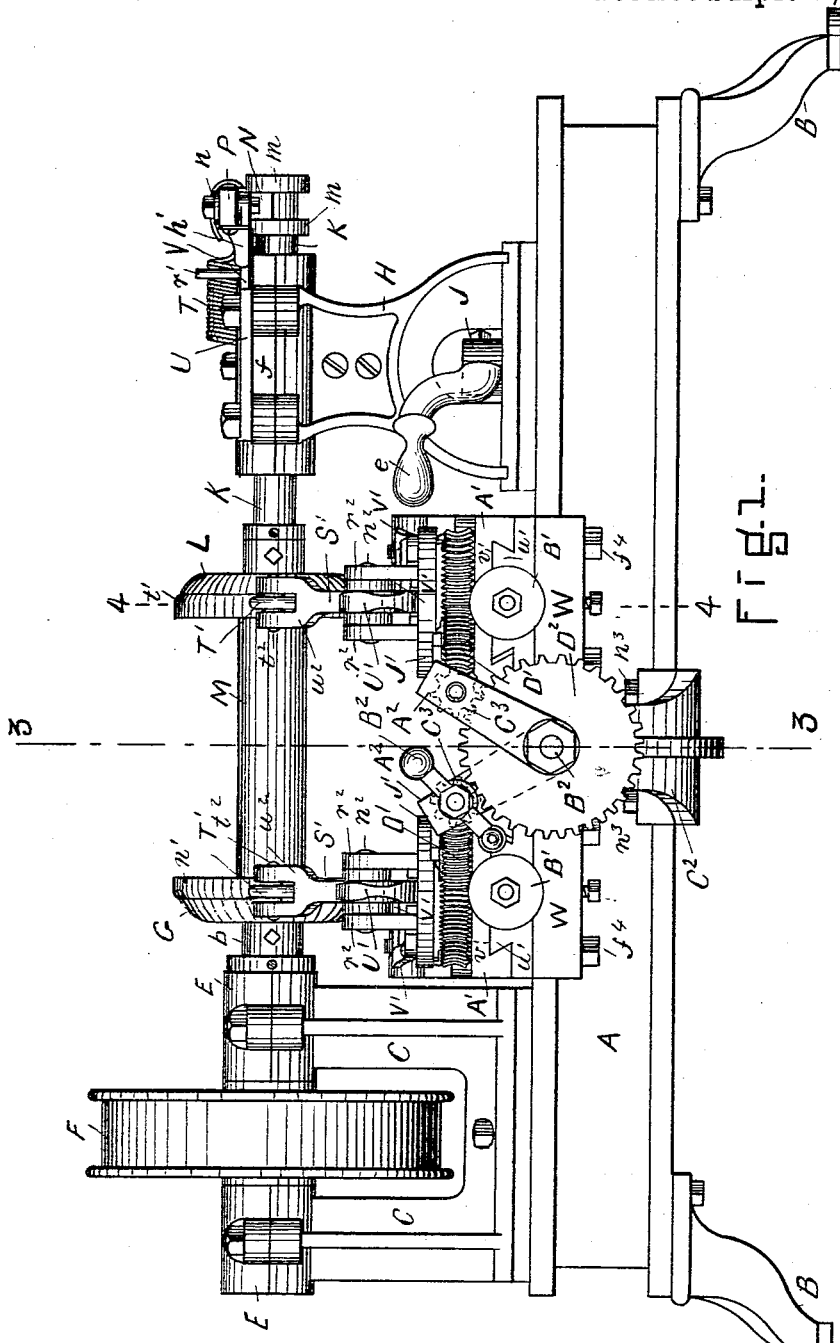

FIG. 1.

WITNESSES.

George W. Litchfield
Leonard C. Adams

INVENTOR.

Alfred T. Tregurtha
Per Edwin M. Brown
Attorney.

A. T. TREGURTHA.

MACHINE FOR APPLYING METAL COVERINGS TO SPOOL HEADS.

No. 557,729.

Patented Apr. 7, 1896.

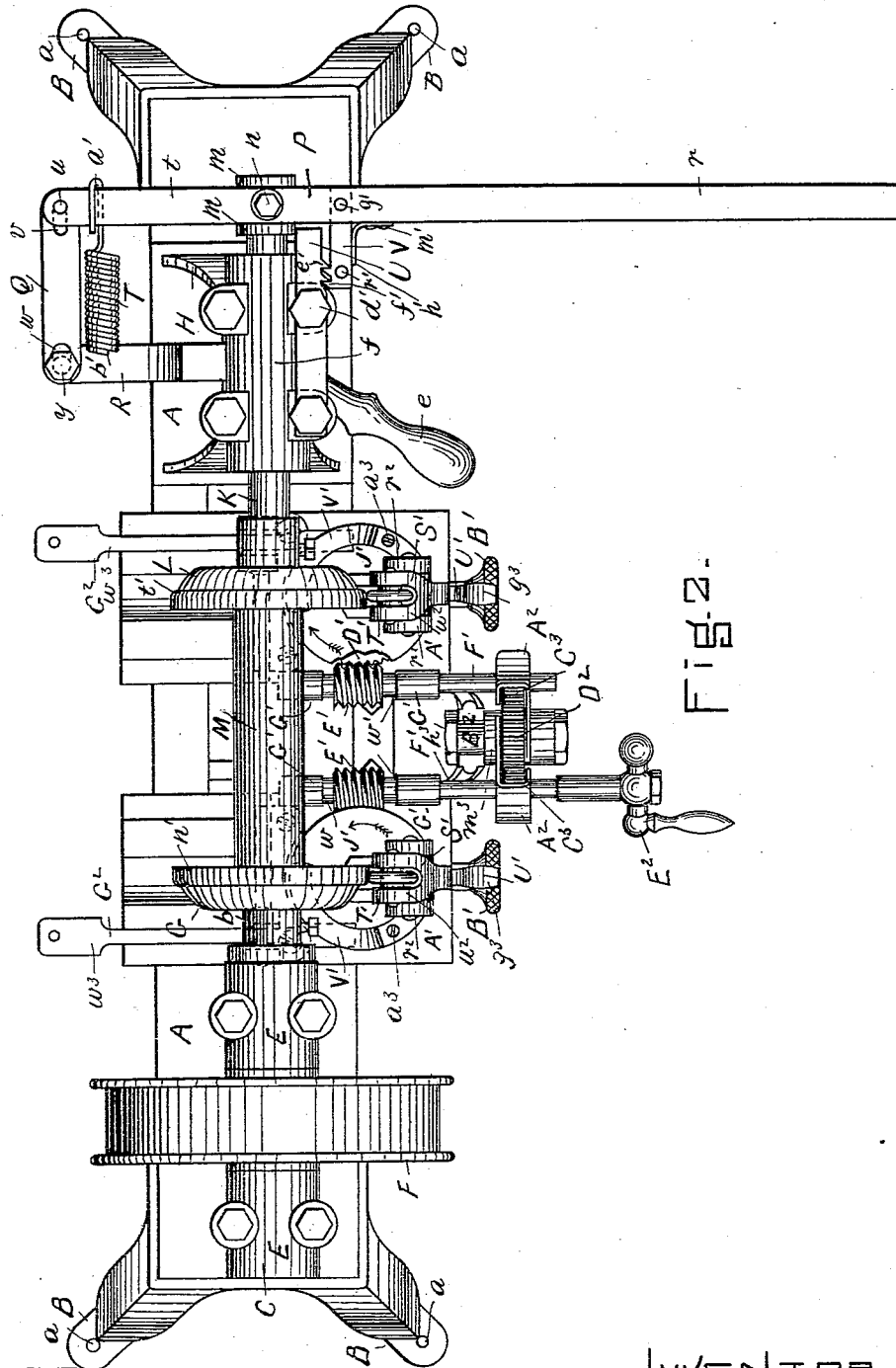

FIG. 2.

WITNESSES.

George R. Littlefield
Leonard C. Hines

INVENTOR.

Alfred T. Tregurtha
Per Edwin M. Beaman
 Attorney.

(No Model.)

5 Sheets—Sheet 3.

A. T. TREGURTHA.

MACHINE FOR APPLYING METAL COVERINGS TO SPOOL HEADS.

No. 557,729.

Patented Apr. 7, 1896.

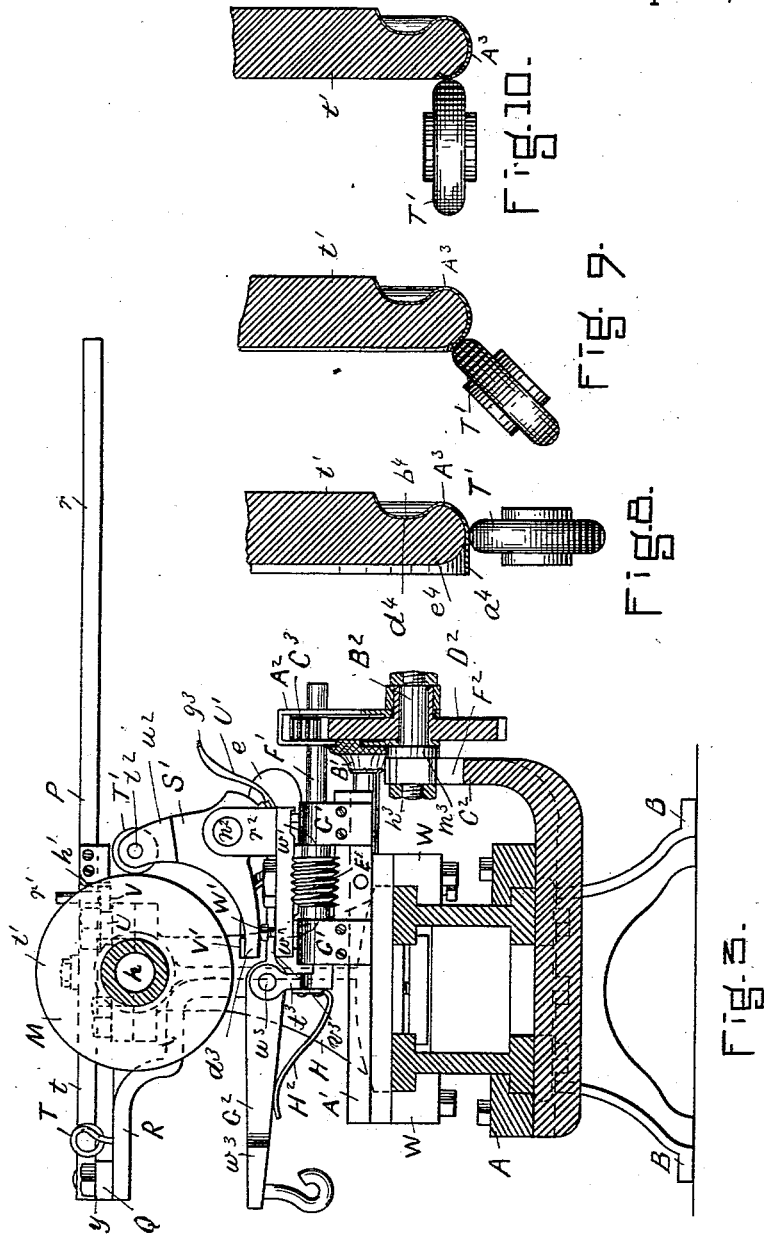

WITNESSES.

George W. Leitchfield
Leonard C. Hunt

INVENTOR.

Alfred T. Tregurtha
Per Edwin W. Brown
Attorney.

A. T. TREGURTHA.

MACHINE FOR APPLYING METAL COVERINGS TO SPOOL HEADS.

No. 557,729.

Patented Apr. 7, 1896.

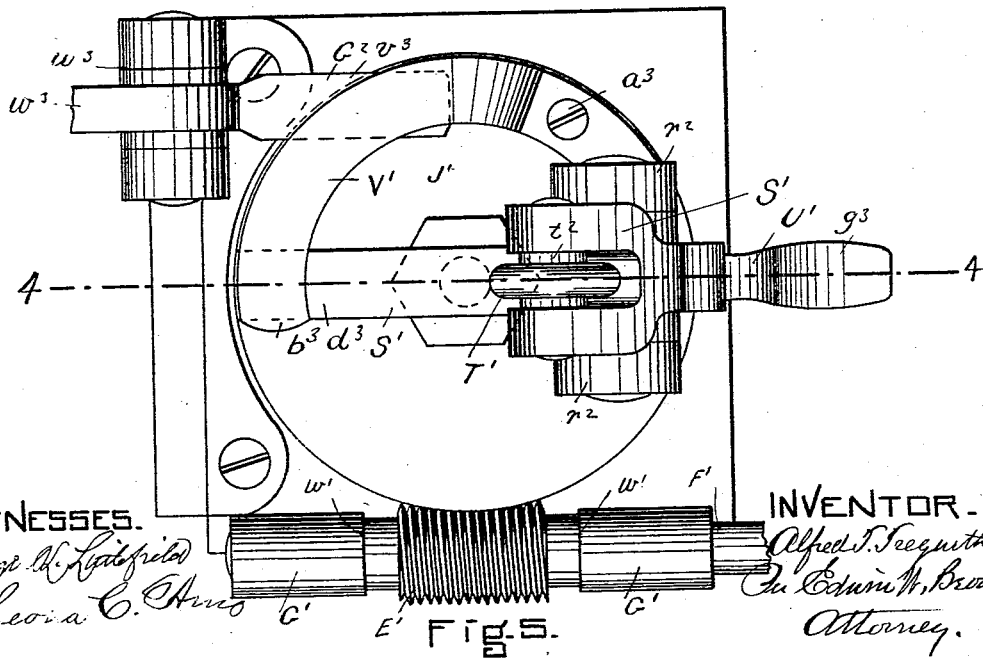
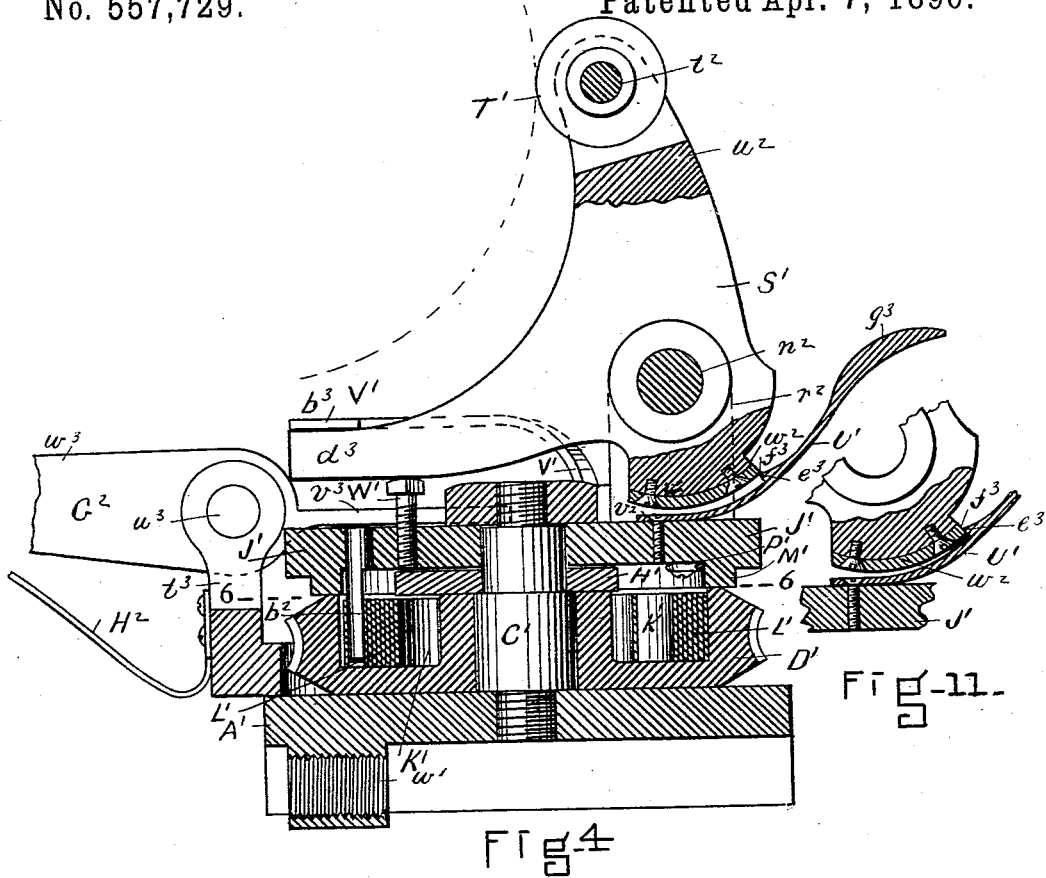

WITNESSES.

George W. Laubfried
Leora C. Arms

INVENTOR.

Alfred T. Tregurtha
Edwin W. Brown
Attorney.

A. T. TREGURTHA.

MACHINE FOR APPLYING METAL COVERINGS TO SPOOL HEADS.

No. 557,729.

Patented Apr. 7, 1896.

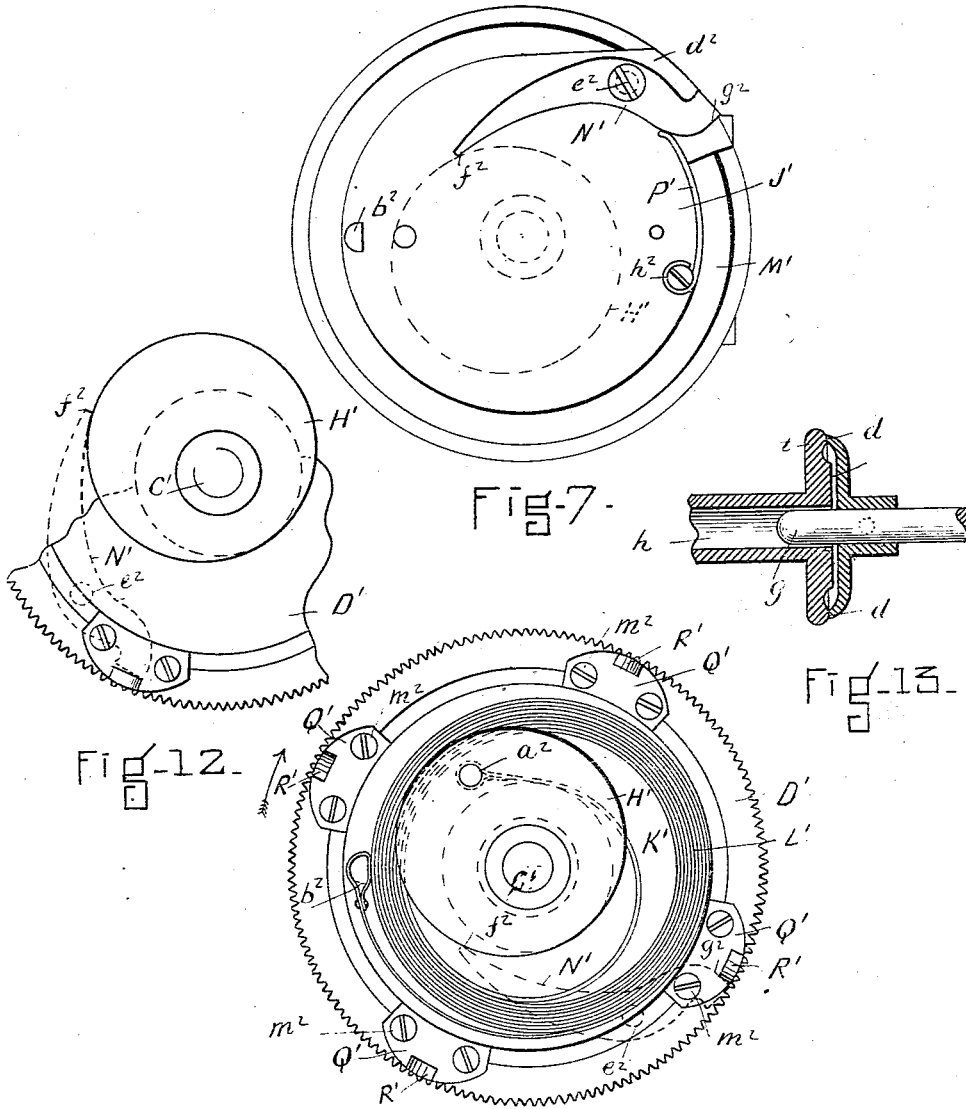

WITNESSES.
George M. Lindqvist
Leonard C. Hines

FIG. 6-

INVENTOR.
Alfred T. Tregurtha
Per Edwin M. Brown,
Attorney.

UNITED STATES PATENT OFFICE.

ALFRED T. TREGURTHA, OF EVERETT, MASSACHUSETTS, ASSIGNOR, BY
MESNE ASSIGNMENTS, TO THE BOYNTON MANUFACTURERS' SUPPLY
COMPANY, OF PORTLAND, MAINE.

MACHINE FOR APPLYING METAL COVERINGS TO SPOOL-HEADS.

SPECIFICATION forming part of Letters Patent No. 557,729, dated April 7, 1896.

Application filed September 24, 1892. Serial No. 446,809. (No model.)

To all whom it may concern:

Be it known that I, ALFRED T. TREGURTHA, of Everett, in the county of Middlesex and State of Massachusetts, have invented certain new and useful Improvements in Machines for Applying Metal Coverings to Spool-Heads, of which the following is a full, clear, and exact description.

This invention relates to a machine for covering the edges of the heads of spools or bobbins with metal in accordance with Letters Patent of the United States, for improvements in spools or bobbins, dated August 5, 1890, No. 433,885; and the invention consists of a machine constructed and arranged to cover the edges of heads of spools or bobbins, all substantially as hereinafter fully described, reference being had to the accompanying sheets of drawings, in which is illustrated a machine in accordance with this invention, in which—

Figure 1 is a front view. Fig. 2 is a plan view. Fig. 3 is a vertical cross-section on line 3 3, Fig. 1. Fig. 4 is a vertical cross-section on line 4 4, Figs. 1 and 5. Fig. 5 is a detail plan view. Fig. 6 is a plan view of one of the parts below line 6 6, Fig. 11. Fig. 7 is an under plan view of one of the parts just above the part shown in Fig. 6. Figs. 8, 9, and 10 are detail sections of a head of a spool, showing the manner of covering its edge with the metal in the operation of the machine to be hereinafter referred to. Fig. 11 is a detail section of some of the parts in Fig. 4 on same section-line, but showing parts in different positions. Fig. 12 is a detail view of a portion of Fig. 7, showing parts in different positions. Fig. 13 is a detail cross-section of a spool-head and the parts holding it. All the figures, except Figs. 1, 2, and 3, are enlarged.

In the drawings, A represents a lathe-bed having feet B and adapted to rest on a suitable bench and be secured thereto by screws passing through holes *a* in the feet B.

C is a head or standard rigidly secured to the lathe-bed A at the left, Figs. 1 and 2, which head has a horizontal shaft D arranged to turn in bearings E in the head and having a pulley F secured to the shaft between the bearings for operation by a belt in the usual manner. Secured to the inner end of the

shaft by a flange *b* is a circular plate or disk G, having its outer side hollowed out or concave to leave a narrow bearing-surface *d* near the edge. On the other end of the lathe-bed is a standard H, adapted to fit upon the lathe-bed and be moved back and forth thereon in the usual manner of arranging such standards on a lathe-bed, and which standard, when moved along the bed to any point desired, is secured by a screw-nut J having a handle *e*. This standard has in a bearing *f* in its upper end a horizontal shaft or rod K adapted to freely turn and move forward and backward longitudinally in the bearing, which shaft or rod centers with the shaft D, as usual in lathes, and it has secured to its inner end a circular plate or disk L having its outer side concave and having a bearing-surface *d* near the edge like the other plate G. (See Fig. 13.) In between these two disks or heads G L is placed the spool M to be operated upon, a center pin *g* of each shaft projecting beyond its respective disk and entering the central socket *h*, as shown in Fig. 13, in the spool M, which centers it in the machine.

On the outer end of the shaft K are two circular flanges *m*, between which is a box or bearing N, on the shaft, to which box, on its upper side, at *n*, is pivoted a horizontal lever P, having a handle *r*, extending forward, its other arm *t* extending back and being pivoted at *u* to a link Q in a longitudinal slot *v*, which link at its other end by a longitudinal slot *w* is pivoted at *y* to a bracket-arm R of the standard H. A spiral spring T is secured by one end to the lever at *a'* and by its other end to the bracket at *b'*, and it acts to hold said lever back and to return it thereto after it has been moved in the opposite direction.

Secured to the standard H by one of the screws *d'* of the bearing is a strip or bar U, having on its edge two ratchet-teeth *e'*, with which are adapted to engage two projecting teeth *f'* of a flat piece V pivoted to the lever P at *g'* and having a flat spring *h'* secured to the lever at *m'*, arranged to bear by its free end against the pivoted piece to hold it to its engagement by its teeth *f'* with the teeth *e'* of the bar U when the lever is moved into position therefor.

To secure the spool M by its socket *h* over the center pin of shaft D, between the two heads G L place one end of the spool, its head *n'* bearing against the disk G, and release the nut J of the standard H by turning its handle to the right, Fig. 2. Then release the lever-piece V from its engagement with the bar U, if not already released, which can be done by taking hold of an upright pin *r'* of the piece and moving it forward therefrom. Then move the standard H along the bed to the left until its shaft-pin *g* enters the spool-socket and its disk L bears and presses against the other head *h'* of the spool. Then press the lever to the left, which forces the shaft K by its connection with it by the flanges *m* along its bearing and moves and presses its disk against the spool-head and the spool closely between the two disks, moving the standard back somewhat, and when it has moved back enough for the bar-teeth *e'* to be nearly to the teeth *f'* of the pawl U of the lever the nut-handle *e* is turned to the left, which sets the nut and securely fastens the standard to the bed at such place. Then the handle portion *r* of the lever P is pressed to the left against its spring until its pivot-piece or interlocking pawl V engages with the bar-teeth *e'* on the standard H, which by its spring will then hold the spool firmly between the two disks G L by a constant pressure, so that by turning the shaft D the spool will be turned with it for operation thereon.

To remove the spool from the machine, move the lever P to free the pawl V from the bar U. Then move the pawl V back by its pin *r'*, disengaging it from the bar U, and then move the lever back, which moves the shaft K back, leaving the spool free to be taken from the machine, when another can be placed therein in position, as before, the standard H remaining set for the same-sized spool.

The slots *v w* in the link-piece Q allow sufficient movement of the lever P against its spring, after the standard is set for it to be moved, to press the disk L and head firmly against the spool.

W is a block adapted to move back and forth along the lathe-bed by its under shouldered grooves, and having an upper dovetail tongue or rib *u'*, over which is a plate A', which has a dovetail groove *v'* on its under side to fit over the block-tongue *u'* and which can slide back and forth thereon and transversely to the lathe-bed, being operated by a screw B', which screws into the plate A' at *w'*, the turning of the screw moving the plate A' back and forth on the block W and transversely in relation to it and the lathe-bed, all substantially as usual in lathes and needing no more particular description herein.

C is a central vertical pin screwing into the plate A' to be rigidly connected thereto, and resting on the plate and adapted to turn on the pin C' is a worm-gear D' engaging with a worm E' on a horizontal rod or shaft F' turning in bearings in blocks G' secured to the

edge of the plate A', the rod having shoulders to bear against the adjacent ends *w'* of the blocks to prevent longitudinal movement thereof.

Above the worm gear-wheel D' is a disk or cam-plate H', (shown in plan in Fig. 6,) eccentrically secured to the pin C', and above this cam-plate H' is a disk or circular plate J' adapted to revolve on the pin C'.

The worm-gear D' has an annular chamber K' in its upper side, in which is disposed a flat coiled spring L' secured by its inner end to a pin *a*² of the cam-plate H' and by its other end to a downwardly-projecting pin *b*² of the disk J'. The under side of the disk J' has a circular rim M' forming a chamber D, in which is disposed the cam-plate H', and to the under side of the disk, in an opening *d*² in the rim, is pivoted at *e*² a pawl N', its pointed end *f*² extending into the disk-chamber, as shown in Fig. 7, and arranged to bear against the edge or periphery of the cam-plate H', as shown in dotted lines in Figs. 6, 7, and 12, and its other right-angular end *g*² adapted to project at certain times beyond the outer periphery of the rim M', as shown in Fig. 7, to be hereinafter referred to, it being held to such position by a spring P' secured at *h*² to the inside of the disk J' in the chamber to bear by its free end against the end of the pawl, as shown in Fig. 7, for such purpose.

In depressions in the upper side of the rim of the gear D', secured by screws *n*² at regular intervals apart, are plates Q', each of which has an upwardly-projecting lug R', which when the circular plate J' is in place over the cam-plate H' and gear D' projects into the space beyond the rim M' of the plate J', so that at certain times when the plate J' is turned on the pin C' into certain positions in relation to the cam-plate H' the end *g*² of the pawl N' will be swung outward for it to be in the line of travel of the lugs R' and abut by its end *g*² against one of them, as shown in dotted lines in Fig. 6, being held there by its spring P', so that as the gear is turned it will by such connection carry around with it the plate J' and its pawl, and as the pawl bears against the edge of the cam H' its end *f*² will be gradually moved outward, and at a certain point on the cam end it will have moved outward sufficient for its arm *g*² to be free of the lug R' of the gear with which it is engaged, as shown in detail in Fig. 12, leaving the plate free to be swung back to its starting position by the action of the coiled spring L', which in such turning movement of the plate has been wound up, and in such return movement the pawl will travel back along the edge of the cam to its first position by its spring forcing outward its end *g*² into position to abut against the next lug R' of the gear, and thus engage its plate J' again with the gear to be turned with it, as before, to be released again when moved so far by the cam and returned to its first position again and be engaged therewith, as before, and so on.

Pivoted at n^2 between two uprights r^2 on the upper side of the plate J' is a vertical angular arm S' having pivoted at t^2 in the upper end of its upwardly-projecting arm w^2 a roller T' .
 5 Under this angular arm, near its pivot, is a spring U' secured by its inner end to the plate J' at v^2 , which presses upward against a plate w^2 secured by screws to the under side of the angular arm, its outer surface being in a line
 10 substantially concentric to its pivot.

V' is a flat spring secured to the top of the plate J' by one end at a^3 and extending round in a curved line and bearing by its free end b^3 on the upper side of the horizontal arm d^3
 15 of the angular arm S' to hold it down, the arm being limited in its downward movement by resting on a screw W' screwing into the plate J' , the screwing in or out of which adjusts the height of its bearing-surface. This spring V'
 20 has a notch or shoulder e^3 on its upper side, against which the end or shoulder f^3 of the angular lever is arranged to bear at times and which by its engagement therewith, as shown in Fig. 11, serves to hold the roller end of the
 25 angular arm back a certain distance, and preventing its moving forward until it is released by pressing down upon the thumb end g^3 of the spring V' , when the arm S' by the action of the spring U' will be swung forward and its
 30 shoulder just past the shoulder of the spring V' , as shown in Fig. 4. This angular arm is so situated in regard to the spool placed in the machine that its wheel or roller T' will bear upon the edge or periphery of the spool-head,
 35 and when it is in its normal position—that is, its shoulder e^3 engaged with the shoulder f^3 of the spring V' , as shown in Fig. 11—its wheel T' will be moved away a short distance from the spool-head; but when the spring U' is
 40 pressed down to release the arm its spring V' acts to move the roller end of the arm forward, which brings the roller to bear firmly against the edge or periphery of the spool-head, as shown in Fig. 4 in dotted lines, and when in
 45 such position the central vertical line of the wheel will bear upon the spool edge at the central line of the spool-head, as shown in detail in Fig. 8, and the arm is so arranged that the central axial line of the wheel will be in the same horizontal plane of the central longitudinal axial line of the shafts carrying spool-holding plates or disks, as shown in Figs. 1, 2, and 3 more particularly.

The stop-screw W' is adjusted so that the
 55 arm S' will not rest thereon at the time the wheel is bearing on the spool edge, in order that the full strength of the spring V' shall act thereon, but it stops the arm from moving too far when the spool is not in the machine.
 60 As there are two heads of the spool to be covered, and as it is desirable that in the operation of the machine both should be covered at once, the transverse plate, angular arms, its gear d' and parts connected therewith are
 65 duplicated, there being one set for each head, as shown in Figs. 1 and 2, each set being constructed alike and which are lettered alike,

but each having a separate worm E' , which are arranged on the opposite side of their respective worm-gears, as shown in plan view
 70 in Fig. 2, for the following reasons: In Figs. 1 and 2 the angular arm S' at the right in operation should and does swing to the left and the angular arm at the left should and does
 75 swing to the right, as shown, respectively, by the arrows in Fig. 2. Therefore, although the worms turn in the same direction, being on opposite sides of the gears, as shown, they operate to turn the gears in the required and
 80 opposite directions.

The shaft or arbor F' of each worm extends forward and turns in separate bearing-plates A^2 , which are firmly secured to an arbor or pin B^2 which is secured to a bracket C^2 of the lathe-bed by screw-nut h^3 and shoulder m^3 ,
 85 and each worm-shaft has a small gear C^3 which engages with a larger gear D^2 arranged between them, adapted to turn on said arbor B^2 .

The worm-shaft F' at the left extends beyond the bearing to have a handle E^2 secured thereto by which it can be turned, which is
 90 to the right, Figs. 1 and 2, and by the gear D^2 motion is communicated to the other worm-shaft. The bracket is secured by bolts n^3 to the under side of the lathe-bed, and the arbor
 95 B^2 is secured in a vertical open slot F^2 in the bracket, so it can be moved up and down to adjust its height, and when adjusted it is tightened by its screw-nut h^3 , which firmly secures the bolt or arbor in its place on the
 100 bracket. Turning this worm by its handle E^2 to the right by its gear C^3 and gear D^2 , connecting with the other gear C^3 of the other worm, the other worm-gear is turned in the same direction; but as they are on opposite
 105 sides of the worm-gears the worm-gears are turned to the right and left correspondingly.

To upright arms t^3 of each plate A' is pivoted at v^3 a lever G^2 , which by one arm v^3 extends under the spring V' on its respective
 110 plate, their other ends w^3 extending back for operation thereof, and which can be done by connecting both with a treadle for operation of both at the same time or independently if desired. This lever G^2 is held up by a spring
 115 H^2 secured to the arm t^3 , by which its end v^3 is kept from interfering with the movements of the angular arms S' , except as above described. These levers are for the purpose of raising the springs V' off the angular arms
 120 when desirous of having the angular arms released from their pressure upon the spool-heads to allow the springs U' to act to engage their shoulders e^3 with the shoulders f^3 on the under side of the angular arms, and
 125 these levers are operated for such purpose when the angular arms have been swung by their gears the requisite distance and it is desired to return them to their normal position for operation again.

The metal A^3 to be placed over each head of the spool is first cut out of a flat sheet of metal of the proper thickness in circular form, and in such die the outer edge a^4 is turned
 130

over at right angles thereto, as shown in cross-section in Fig. 8. It is then placed in another die and punch, the central portion cut out, and the part next thereto pressed and
 5 molded into the outline shown in cross-section at b^4 in Fig. 8. Each spool-head is then turned previously in a lathe to have its head edge round in cross-section with a flat groove in its outer side at d^4 to receive the portion b^4
 10 of the metal plate and preferably a small narrow groove in the inside at e^4 , the width of the plate being sufficient to extend over the edge of the spool-head as desired and be disposed in the grooves.

15 To operate the machine, two of the metal coverings being prepared as described are placed one over each spool-head, as shown in Fig. 8, and the spool placed in the machine as before described, and the pulley set in
 20 motion, which revolves its shaft and spool with it. The two rollers do not yet bear upon the spool-heads, but press down the two springs U^7 , which relieves them from their interlock with the angular arms S' , allowing
 25 their springs V' to act upon them to press their rollers against their respective spool-heads, each one bearing against the metal at the central line of the curve, as shown in detail in Fig. 8. The handle E^2 of the worm-screw at the left is now turned to the right,
 30 which turns the gears carrying their respective plates and rollers to the left and to the right, the edges of the rollers in their horizontal travel moving in the path of a circle and being held firmly to their bearing on the
 35 metal by their springs. As the rolls are carried round the edge of each head the metal covering to each head is rolled and forced around the edge of the head to its inner side, the rolls taking the several positions and in
 40 continuation thereof shown in detail in Figs. 8, 9, and 10, and when at the edge of the metal, as shown in Fig. 10, the pressure of the springs V' forces the rolls to turn the edge of the metal into a groove in the outside of
 45 each head or compresses the metal into the head at such place if no groove is provided. When thus fully covered, the levers G^2 are pulled down at their outer ends, which then
 50 by their inner ends bear up against the under side of the springs and raise the springs from the angular arms, (which by their rotating movement have moved into such position over the inner ends of the levers,) which swings
 55 them against their springs and the rolls from their bearings on the spool-heads, so that the arms engage by their shoulders f^3 with the shoulders c^3 of the springs U' , which holds them in such position and leaving them free
 60 so the coiled springs L' can then act to swing back the plates and their angular arms into their normal positions ready for operation upon other spools, as before.

The cam-plates H' are stationary, and as the
 65 gears D with their plates and roller-arms are turned on their axes their respective pawls N are carried round with them, and in such

movement their inner ends move along the cam edge from the position shown by dotted lines in Fig. 6 to the position shown by dotted
 70 lines in Fig. 12 for the right-hand angular arm, and being gradually forced outward their ends g^2 are correspondingly moved inward and away from their engagement with the lugs R' of the worm-gear, and by the
 75 time the rolls or wheels have completed their movements and work on each spool-head the pawls will be disengaged from the lugs R' , leaving their respective circular plates free to be acted upon by their coiled springs $L' L'$
 80 immediately the pressure of the springs is relieved from the angular arms, and as the plates move back their pawls also move back along the portions of the cam over which they have traveled and by the action of their springs P'
 85 their arms f^2 are moved inward and their ends g^2 outward to strike and bear against the next lugs R' , stopping their plates and angular arms, &c., in positions shown in Fig. 2 and ready for action, as before, on the heads of
 90 another spool.

As the gears and their plates travel in opposite directions, the cam-plates are reversed accordingly, the cam at the right being shown in plan in Fig. 6 and the cam at the left being
 95 opposite thereto, but not shown.

When desirous of covering the heads of spools which are longer or shorter than the one shown, the blocks or plates W , carrying the angular arms, are moved along the lathe-bed
 100 either to or from each other, according as the spool is longer or shorter, by unscrewing the bolts f^4 , which allows the plates to be moved along the lathe-bed the proper distance apart, which are then secured in place by
 105 tightening up the bolts, and if the heads are of smaller or larger diameter turning the screw B' to the right or left will correspondingly move the plates A' on their respective blocks and adjust them to the desired positions, and in case of these readjustments the arbor B^2 to the gear D^2 is loosened and its height adjusted in the slot E^2 in the bracket C^2 to place the gear so it will properly engage
 110 with the worm-gears C^3 to suit their changed positions to the right or left, and when the gear is brought to its position the arm is firmly secured in the bracket. Obviously for extremely large spools a machine correspondingly enlarged would be necessary, the present machine practically being limited to certain sizes of spools.

Having thus described my invention, what I claim is—

1. In combination, a lathe or other suitable
 125 support for a spool or other article, to be rotated thereon, an arm pivoted to a suitable support, a spring bearing upon said arm, a roll or wheel pivoted to said arm arranged to bear upon the spool or other article in the
 130 lathe.

2. In combination, a lathe or other suitable support, for a spool or other article to be rotated thereon, an arm secured to a worm-gear,

a worm engaging with said worm-gear, a spring bearing upon said arm, a roll or wheel pivoted to said arm and arranged to bear upon the spool or other article.

5 3. In combination, a lathe or other suitable support for a spool or other article to be rotated thereon, an arm pivoted to a suitable support, a shoulder on said arm, a spring bearing upon one end of said arm, another spring
10 upon a support having a notch or shoulder and arranged to bear against and engage with the shoulder of said arm, and a roll or wheel pivoted to said arm and adapted in the turning
15 of the arm to bear upon the spool or other article in the lathe.

4. In combination, a lathe or other suitable support for a spool or other article to be rotated thereon, an arm secured to a worm-gear, lugs or stops on said worm-gear, a worm engaging with said worm-gear, a spring bearing
20 upon one end of said arm, a spring-pawl pivoted to said worm-gear to engage with said lugs, an eccentric cam secured to a suitable support for operation of said spring-pawl in
25 the turning of the worm-gear and a roll or wheel pivoted to said arm and adapted in the turning of the arm to bear upon the spool or other article in the lathe.

5. In combination, a lathe or other suitable support for a spool or other article to be rotated thereon, an arm pivoted to a suitable support, a spring bearing upon said arm, another spring secured by one end to a suitable support and by its other end to the rotating
30 support of said arm, and a roll or wheel pivoted to said arm and adapted in the turning of the arm to bear upon the spool or other article in the lathe.

6. In combination, a lathe or other suitable support for a spool or other article to be rotated thereon, an arm secured to a worm-gear, lugs or stops on said worm-gear, a worm engaging with said worm-gear, a spring bearing upon
40 one end of said arm, a spring-pawl pivoted to said worm-gear to engage with said lugs or stops, an eccentric cam secured to a suitable support for operation of said spring-pawl in the turning of the worm-gear, a spring secured by one end to the worm-gear, by its other end
45 to a suitable support and a roll or wheel pivoted to said arm and adapted in the turning of the arm to bear upon the spool or other article in the lathe.

7. In combination, a lathe or other suitable support for a spool or other article to be rotated thereon, a worm-gear, lugs or stops on said worm-gear, a worm engaging with said worm-gear, a spring-pawl pivoted to said worm-gear
55 to engage with said lugs or stops, an eccentric

cam secured to a suitable support for operation of said spring-pawl in the turning of the worm-gear, an arm secured to said worm-gear and a roll or wheel pivoted to said arm and adapted in the turning of the arm to bear upon the spool or other article in the lathe. 6c

8. In combination, a lathe or other suitable support for a spool or other article to be rotated thereon, an arm pivoted to a suitable support, a shoulder on said arm, a spring secured to a support and bearing upon one end of said arm,
65 another spring having a notch or shoulder and arranged to bear against said arm and engage with the shoulder of said arm, a lever pivoted to a suitable support, and arranged to operate said arm against its spring and a roll or wheel
70 pivoted to said arm and adapted in the turning of the arm to bear upon the spool or other article in the lathe. 65

9. In combination, a lathe having two shafts axially opposite to each other, a center pin to each shaft a disk or plate secured to each shaft, said disks or plates being hollowed out on their contiguous faces leaving a bearing-surface at or near their respective edges. 80

10. In combination, a lathe having one fixed and another movable standard, a shaft in each standard, a lever pivoted to the shaft in said movable standard, a link pivotally connected by one end to said lever, and by the other to a support, the bearings in said link for said
85 pivot being elongated, a spring to said lever, a notched bar secured to said standard and a notched spring-pawl secured to said lever to engage with said notched bar. 85

11. In combination, a lathe having one fixed and another movable standard, a shaft in each standard, a lever pivoted to the shaft in said movable standard, a link yieldingly connected by one end to said lever and by the other to a support, a spring to said lever, a notched bar
90 secured to said standard and a notched spring-pawl secured to said lever to engage with said notched bar. 95

12. In combination, two arms each secured to a separate worm-gear, a worm-gear to each worm-gear, a spring to each arm, a roll or wheel pivoted to said arm, a gear upon each worm-shaft, and an intermediate gear engaging with both of said gears and adjustably secured to a suitable support. 105

In testimony whereof I have hereunto set my hand in the presence of two subscribing witnesses. 110

ALFRED T. TREGURTHA.

Witnesses:

EDWIN W. BROWN,
CARRIE E. NICHOLS.